



*Wasco Skywindow Brand Skylights
Glass Replacement Instructions*

207-324-8060

800-388-0293

Models EF/EV/GA/GS/GV1

1. Check replacement glass when received and report any damage to delivering carrier. Insure proper size and that all materials listed in the packing list were received. Identify specific unit type from drawings on reverse side and use as reference to written instructions when replacing glass.

PACKING LIST

1 Instruction Sheet
1 Piece Insulated Glass

TOOLS NEEDED

Phillips Screwdriver #2
3/16" Slotted Screwdriver
Work Gloves

OPTIONAL

1 Retainer Frame w/Glazing Blocks Inserted
1 Bag of Retainer Screws

2. Remove all retainer screws (2) from the unit and put aside.
3. Remove retainer (3) and old glass (1) from the PVC frame (6). (On older units, the two are adhered together by a butyl seal and should come up as one unit.) Wear gloves at this point to protect your hands.
4. Place new glazing squarely on the skylight frame. The glazing must completely cover the glazing gasket. Pay attention to any labels that may be on the glass specifying which surface to face toward the room. If there are no labels, then either side is fine.
5. Check to insure that the retainer gasket (4) and molded glazing blocks (5) are properly inserted into the underside of the retainer frame. Position one glazing block directly under each screw hole so that the retainer screw is inserted through it. (On older units wood glazing blocks are placed on the PVC frame against the edge of the glazing under the retainer frame at the screws or corners.)
6. Hold the glass firmly in place while replacing the retainer frame. Re-secure the retainer with the old screws. Be sure to thread the screws into the existing screw holes in the PVC frame. **CAUTION: Do not OVERTIGHTEN the screws** as this may strip the threads.
7. Clean the glass and the replacement is complete. Properly dispose of all old materials.

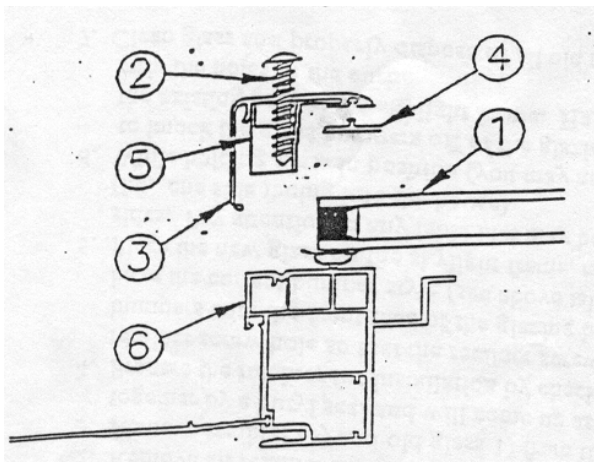

EF Unit

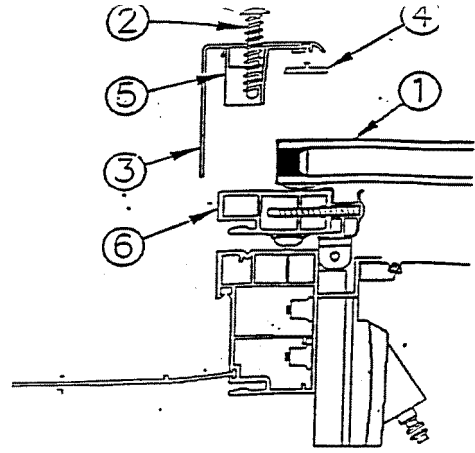

EV Unit

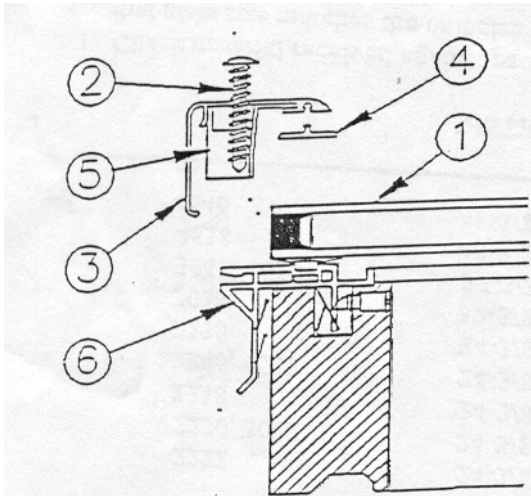

XLF Unit

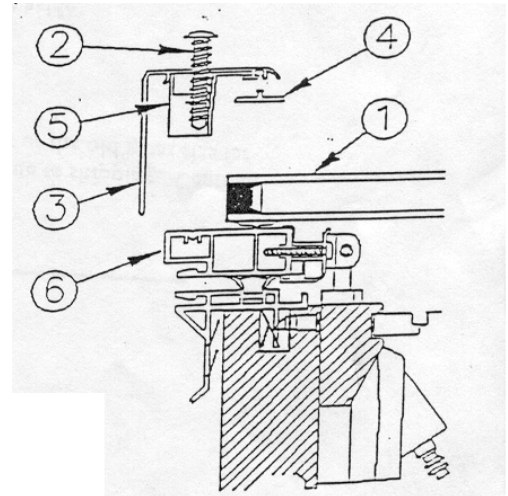

XLV Unit

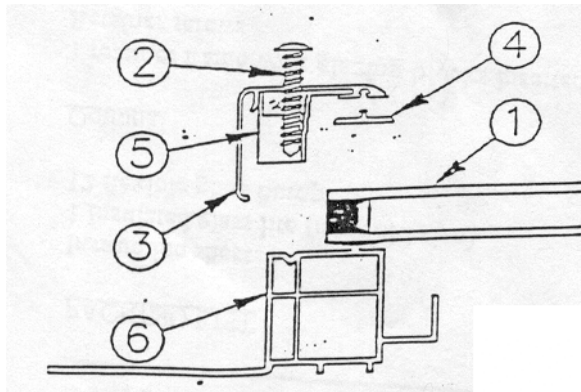

GA Unit (GV1 similar)

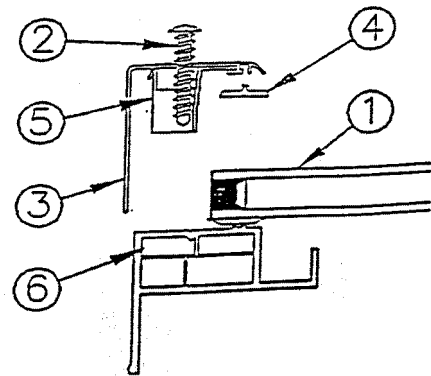

GS Unit

All Units Typical

1. Insulating Glass Unit
2. Phillips Retainer Screw
3. Retainer Frame
4. Gasket (Under Retainer)
5. Molded Glazing Block with Bumper Gasket
6. PVC Frame

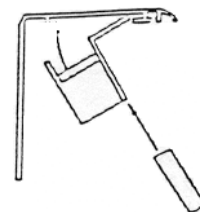

Glazing
Block Detail